



EON TRADING LLC USA

www.eonbg.com ; e-mails: eonbg@eonbg.com ; todorov@eonbg.com ; todorov@sz.intg.bg

EON Trading LLC , USA, State of Dalaware,701 Renner ROAD, Wilmington, Delaware 19810, Country of New Castle.

BULGARIAN OFFICE - Industrial Area, STARA ZAGORA; Tel./Fax:(359 42) 603 449; 62 60 19; Tel. (359 888) 714 711;

Alkotest

Alcohol contents volume percentage analyzer

USER'S GUIDE

CONTENTS:

KEY FEATURES 3

ALKOTEST FRONT AND BACK PANELS 5

ALKOTEST ANALYZER KIT 6

ANALYZER INSTALATION 6

MODES OF OPERATION..... 7

SAMPLE PREPARATION..... 7

MEASUREMENT 8

PRINTIG OUT THE MEASUREMENT RESULTS 8

CLEANING OUT 9

CALIBRATION..... 9

ERROR MESSAGES..... 13

GUARANTEE 13



KEY FEATURES

FIELD OF APPLICATION

Alkotest series Analyzers are intended for measurement of the ethyl alcohol contents in wine distillate and water alcohol mixtures. Using this analyzer the time needed per one analysis is reduced to about a minute (assuming distillation is already done). Alkotest analyzer makes unnecessary the use of such equipment as Analytical Balances, precision water thermostat and picnometers in the process of alcohol contents measurement. It also significantly reduces the human factor influence in the measurement process. Alkotest Analyzers are easy for use and serve. There is no need of specialized glass equipment and qualified personal. The user can easily calibrate the equipment by means of calibrating solutions (standards). It is recommended to check the equipment twice a month and to calibrate it if necessary. The calibration is made in four points: - distilled water (0% alcohol contents), and three standard solutions with accurately determined alcohol contents – one standard solution is required for each of the ranges:

- $9.00 \pm 0.3\%$;
- $11.5 \pm 0.3\%$;
- $14.00 \pm 0.3\%$.

The Analyzer accuracy is $\pm 0.1\%$ volume alcohol contents, in the range from 8% to 15%. The analysis accuracy can be controlled by means of standard alcohol samples, standard wine samples, checking samples and other methods.

KEY FEATURES:

- Portable and lightweight design;
- Cost effective:
 - Low power consumption;
 - Small sample volume – less than 25 cm³;
- Complete User calibration by means of standard solutions;
- RS232 Interface;
- ESC/POS printer support.

MEASUREMENT SPECIFICATION:

Ethyl Alcohol measurement range-	from 8 to 15 % by volume
Resolution -	0,01%;
Repeatability -	±0,04%
Accuracy (absolute) -	±0,1%
Volatile Acid content in the sample no more than	1 g/l;
Time per one measurement (no more than)	110 sec.

POWER SUPPLY:

Mains Voltage	220V/ AC +10/-15% 50/60Hz; (110V/AC Optional)
Cat Battery	12V DC (10.6 to 14.2V);
Power Consumption (no more than)	30W;

ENVIRONMENTAL:

Air Temperature	from 15 to 30 C°
Relative Humidity	from 30 to 80%
Sample Temperature	from 15 to 25 C°

ADDITIONAL FEATURES:

RS232 Computer interface available;	
Serial (ESC/POS) printer output available;	
Size (HxWxD) -	300x95x250 mm;
Weight (no more than) -	4 kg.

ALKOTEST FRONT AND BACK PANELS

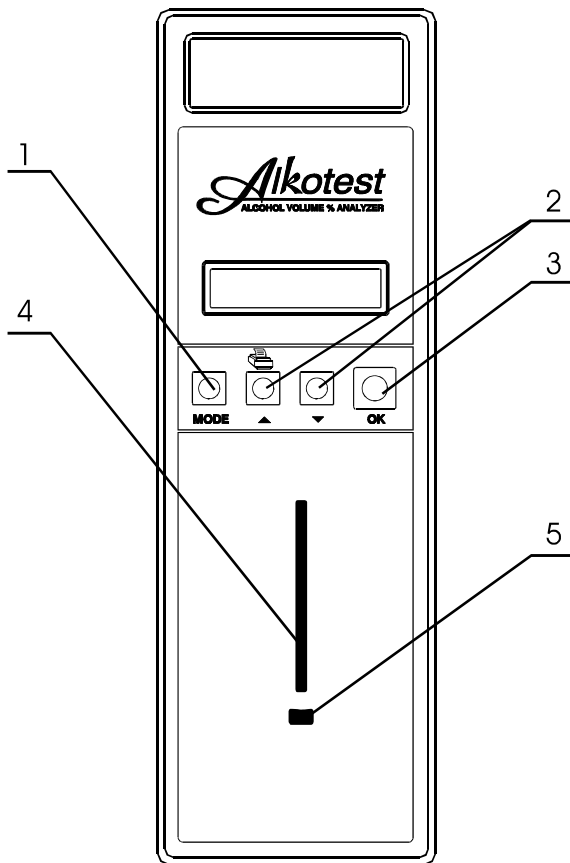

Front Panel

1. MODE/MENU Button
2. Mode select buttons
3. OK button
4. Sample sucking nozzle
5. Measuring mug plastic support

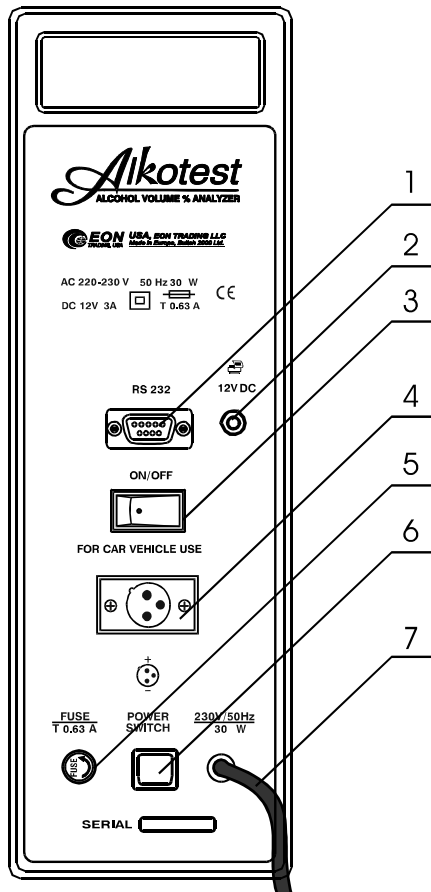

Back Panel

1. RS 232 Connector
2. 12V DC power supply for external printer
3. 12V car battery power supply switch
4. 12V car battery power supply connector
5. Fuse 220V/ 0,63A (110V/1.0A)
6. 110/220V AC power supply switch
7. Power supply cable

ALKOTEST ANALYZER KIT

Pos.	Description	Quantity.
1.	Alkotest Analyzer	1
2.	User's Guide	1
3.	12V power supply cable	1
4.	Standard samples for calibration 3x100mL	1 Set
5.	Measuring mug	2

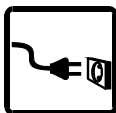

ANALYZER INSTALATION

Before to use the Analyzer for the first time please, take the syringe piston out of the syringe (pos. 1) and insert the plastic plug with rubber O-rings instead (pos. 2).

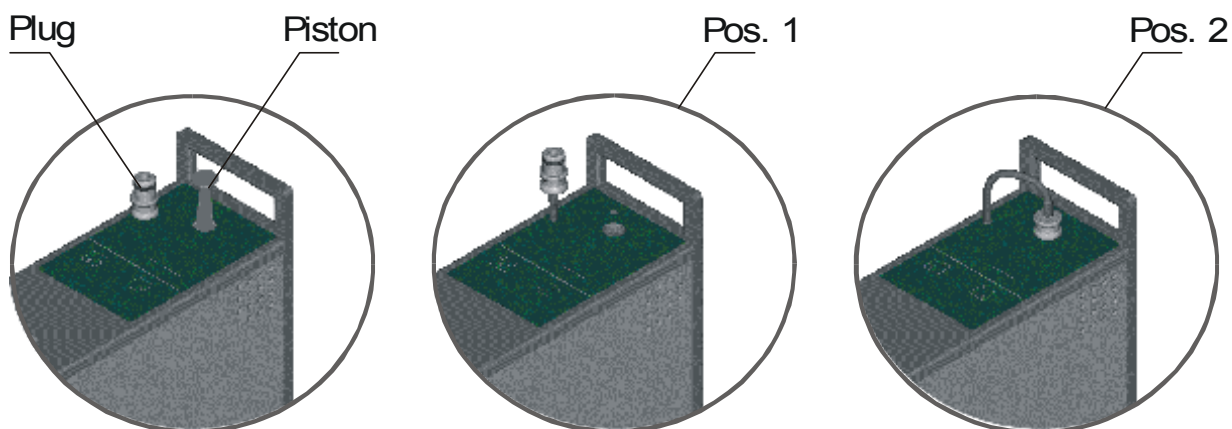

Place the Analyzer vertically on a table or another flat surface and connect it to the power supply:

- AC power supply voltage

Connect the AC power supply plug to the mains socket and set the AC power supply switch to ON;

- 12V DC power supply voltage

Plug the 12V cable connector into the matching back panel 12V power supply connector and connect the other end of the cable to an autonomous DC supply (car battery). Set the 12V Power switch to “ON”.)

Warm up

As soon as the power is on, a **WARM UP** message appears on the display. When the “warm up” stage is over in about 5 minutes, **ALKOTEST** is shown on the display. The Analyzer is ready to use. It is recommended one or two dummy tests to be done as a part of the initial warm up procedure (just leave these test results out of consideration).

Warning: The covers of the Analyzer should never be removed while the power leads are connected.

Warning: Under no circumstance you should try to repair the Analyzer's power lead yourself. In case of power lead damage, contact your dealer to make the repairs.

MODES OF OPERATION

As soon as the **MODE** button is pressed the two main modes of operation will appear on the LCD - **MEASUREMENT** and **CALIBRATION**. The desired mode of operation should be selected first using one of the arrow buttons ▼, ▲ and then it can be started by pressing the **OK** button. After the initial warm up procedure the **MEASUREMENT** mode is selected by default.

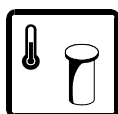

SAMPLE PREPARATION

ALKOTEST ultrasonic analyzers can measure the volume percentage alcohol contents in water – alcohol mixtures or wine distillates. In case wine distillate is to be measured it should be alkalized first in order to remove the volatile acids from it. If this is not done the measurement result may deviate from the real distillate alcohol value. The sample temperature should be in the range from 15 to 25 C°.

MEASUREMENT

Select **MEASUREMENT** mode and press the **OK** button. A “**Load Sample For Cleaning**” message appears on the LCD. Now put in the measuring mug about 20 – 25ml of the tested sample. Place the measuring mug on the front panel plastic support with the sucking nozzle into the sample.

Press the **OK** button again. A “**Cleaning...**” message appears on the LCD and the Analyzer sucks and returns back twice part of the sample. Then a “**Load Sample For Measuring**” message appears on the LCD. Now replace the liquid in the measuring mug with new taken from the same sample and place again the measuring mug on the front panel plastic support with the sucking nozzle into the sample. Press the **OK** button. The Analyzer sucks part of the sample and “**Measuring Mode Working**” message appears on the LCD. The measurement takes about 40 – 45 seconds and the measurement steps are indicated on the Analyzer’s LCD with black squares.

After the measurement completes the sample is returned back to the measuring mug and “**Alcohol: XX.XX%**” message appears on the LCD (XX.XX% represents the alcohol volume contents measured). The measurement result is sent trough the RS232 interface as well.

As soon as a measurement completes and result is saved next sample measurement can be started. The Analyzer is designed for continuous work as long as needed.



PRINTIG OUT THE MEASUREMENT RESULTS (REQUIRES EXTERNAL ESC/POS PRINTER)

As soon as the measurement result is displayed on the LCD it can be printed out as well by pressing “**▲**” button to an ESC/POS printer attached to the back panel RS232 interface connector. Pressing this button again will cause a new copy of the measurement result to be printed out.



CLEANING OUT

When all measurements are done the Analyzer should be cleaned before it is turned off. The cleaning procedure is simple and only requires three successive measurements of distilled water to be made in the way described in chapter “MEASUREMENT”.



CALIBRATION

All **ALKOTEST** ultrasonic analyzers are factory calibrated for ethyl alcohol volume percentage contents measurement in water alcohol mixtures and wine distillates. The specified accuracy of the Analyzer is $\pm 0.1\%$ of alcohol contents in the range from 8.00% to 15.00% alcohol. The analysis accuracy can be controlled by means of standard alcohol samples, standard wine samples, checking samples and other methods. It is recommended **ALKOTEST** Analyzers to be checked once per two weeks and to be calibrated if necessary (in case an Analyzer does not meet the accuracy spec).

Preparing for Calibration

Place the Analyzer vertically on a table or another flat surface and connect it to the power supply. Turn On the Analyzer’s power supply switch. A “**Warm Up ...**” message appears on the LCD. After the initial warm up procedure completes in about 4 – 5 minutes an “**ALKOTEST**” message appears on the LCD which means the Analyzer is ready. Please, make two dummy measurements as a part of the initial warm up procedure (just leave this test results out of consideration). This is made in order to put the ultrasonic sensor in optimal temperature mode for best calibration results.

The calibration procedure requires you to have distilled water and three calibration standards – at least 50ml of each. You should have one calibration standard with alcohol contents in the following ranges: $9.00 \pm 0.3\%$, $11.5 \pm 0.3\%$, $14.00 \pm 0.3\%$.

Calibration

Enter the main menu by pressing the **MODE** button and then select “**Calibration**” mode using the arrow buttons \blacktriangledown , \blacktriangle . Press the **OK** button and a “**Load Water For Cleaning**” message will appear on the LCD. Now put about 20ml distilled water in the measuring mug. Place the measuring mug on the front panel plastic support with the sucking nozzle into the sample.

Press the **OK** button again. A “**Cleaning...**” message appears on the LCD and the Analyzer sucks and returns back twice part of the sample. Then a “**Load Water For Calibration**” message appears on the LCD. Now replace the water in the measuring mug with new and place again the measuring mug on the front panel plastic support with the sucking nozzle into the sample. Press the **OK** button. The Analyzer sucks part of the sample and “**Calibration Mode Working**” message appears on the LCD. The calibration takes about 40 – 45 seconds and the calibration steps are indicated on the Analyzer’s LCD with black squares.

At the completion of this calibration step the Analyzer automatically returns the used water sample and “**Enter Value Alc 1 00.00 %**” message appears on the LCD. Now using the \blacktriangledown , \blacktriangle buttons you have to enter the volume percentage alcohol contents of the first calibration standard – the one whose alcohol contents is in the range $9.00\pm 0.3\%$. Using the \blacktriangledown button you can move the cursor through the alcohol value digits (the alcohol value is set as 00.00% initially) while using the \blacktriangle button you can dial the proper value of the selected digit. Every time you press the \blacktriangle button the selected digit value is incremented. Please be aware pressing \blacktriangle button you can roll over the digit value from 9 to 0.

Example: Let’s assume the calibration standard we use has alcohol contents of 9,13%. In order to enter this value you should press \blacktriangledown , \blacktriangle buttons in the following sequence when the “**Enter Value Alc 1 00.00 %**” message appears on the LCD:

- Press \blacktriangledown button once;
- Press \blacktriangle button 9 times;
- Press \blacktriangledown button once;
- Press \blacktriangle button once;
- Press \blacktriangledown button once;
- Press \blacktriangle button 3 times.

Now it should be shown “**Enter Value Alc 1 09.13 %**” on the LCD.

Press the **OK** button after the calibration standard alcohol contents is correctly dialed. “**Load Sample 1 For Cleaning**” message appears on the LCD. Now put about 20ml of this calibration standard in the measuring mug. Place the measuring mug on the front panel plastic support with the sucking nozzle into the sample and press the **OK** button. “**Cleaning...**” message appears on the LCD and the Analyzer sucks and returns back twice part of the sample. “**Load Sample 1 For Calibration**” message appears then. Now throw away the used sample, fill the measuring mug with sample from the same calibration standard and place again the measuring mug on the front panel plastic support with the sucking nozzle into the sample. Press the **OK** button. The Analyzer sucks part of the sample and “**Calibration Mode Working**” message appears on the LCD. The calibration stage takes about 40 – 45 seconds and the calibration steps are indicated on the Analyzer’s LCD with black squares.

At the completion of this calibration stage the Analyzer automatically returns the used sample and “**Enter Value Alc 2 00.00 %**” message appears on the LCD. Now following the same steps as described above you have to enter the alcohol volume contents of the second calibration standard – the one with alcohol contents in the range $11,5\pm 0.3\%$. Clean and calibrate the Analyzer with this calibration standard in the same way as this has been done with the first standard. At the completion of this calibration stage the Analyzer automatically returns the used sample and “**Enter Value Alc 3 00.00 %**” message appears. Following again the steps described above you have to enter the alcohol volume contents of the third calibration standard – the one with alcohol contents in the range $14.00\pm 0.3\%$. Clean and calibrate the Analyzer with this calibration standard in the same way as this has been done with the first standard. At the completion of this calibration stage the Analyzer automatically returns the used sample “**Calibr. Finished**” message appears on the LCD. This means the calibration procedure has completed successfully and you just need to press the **OK** button in order to start a sample measurement.

A proper calibration of the Analyzer can only be done if the first calibration standard has alcohol contents in the range of $9.0\pm 0.3\%$, the alcohol contents of the second calibration standard is in the range of $11.5\pm 0.3\%$ and third calibration standard has alcohol contents in the range of $14.0\pm 0.3\%$. In case the alcohol contents of any of the calibration standards is out of the required range “**Improper value**” message appears”. In case you want to make calibration using this standard press the **OK** button. If you

need to enter a new alcohol contents value for this calibration standard (if the alcohol content has been dialed wrongly for example) please press the ▼ button first, press the ▲ button next and then release both buttons. This will let you dial again the alcohol contents of the same standard.

WARNING: Using calibration standards with alcohol contents out of the required ranges, using the calibration standards in a sequence different from the required (standard 1 – 9.00±0.3%, standard 2 – 11.50±0.3% and standard 3 – 14.00±0.3%) or entering wrong alcohol contents value of the calibration standards will cause improper calibration and you'll need to calibrate again the Analyzer.

Cleaning

If the Analyzer will be no longer used after the calibration is done it should be cleaned before you turn it Off as described in chapter **CLEANING OUT**.



ERROR MESSAGES

ERROR	ASSEMBLY	PROBLEMS & CAUSES	REMEDY
1. MOTOR ERROR	Pump Motor	Pump Motor does not respond	Turn Off the power supply, then turn it On in 10 seconds and try again to start a measurement.
2. EMPTY CAMERA	Measurment system	There is not enough sample liquid in the measuring mug	Put enough sample liquid..
3. HOT SAMPLE	Measurment system	The sample temperature is too high.	Cool down the sample and try again.
4. IMPROPER VALUE	Measurment system calibration	The calibration standard alcohol contents is out of the required range.	Enter the proper alcohol contents.

GUARANTEE

Guarantee period is one year after purchasing date.

Guarantee is void if warranty labels are removed. Improper handling, transport and storage will invalidate the guarantee. Under no circumstance you should try to repair the Analyzer yourself, as this will invalidate the guarantee. The guarantee conditions for this analyzer are as defined by our representative in the country of sale.

Serial N:

Date:
